

**Base**

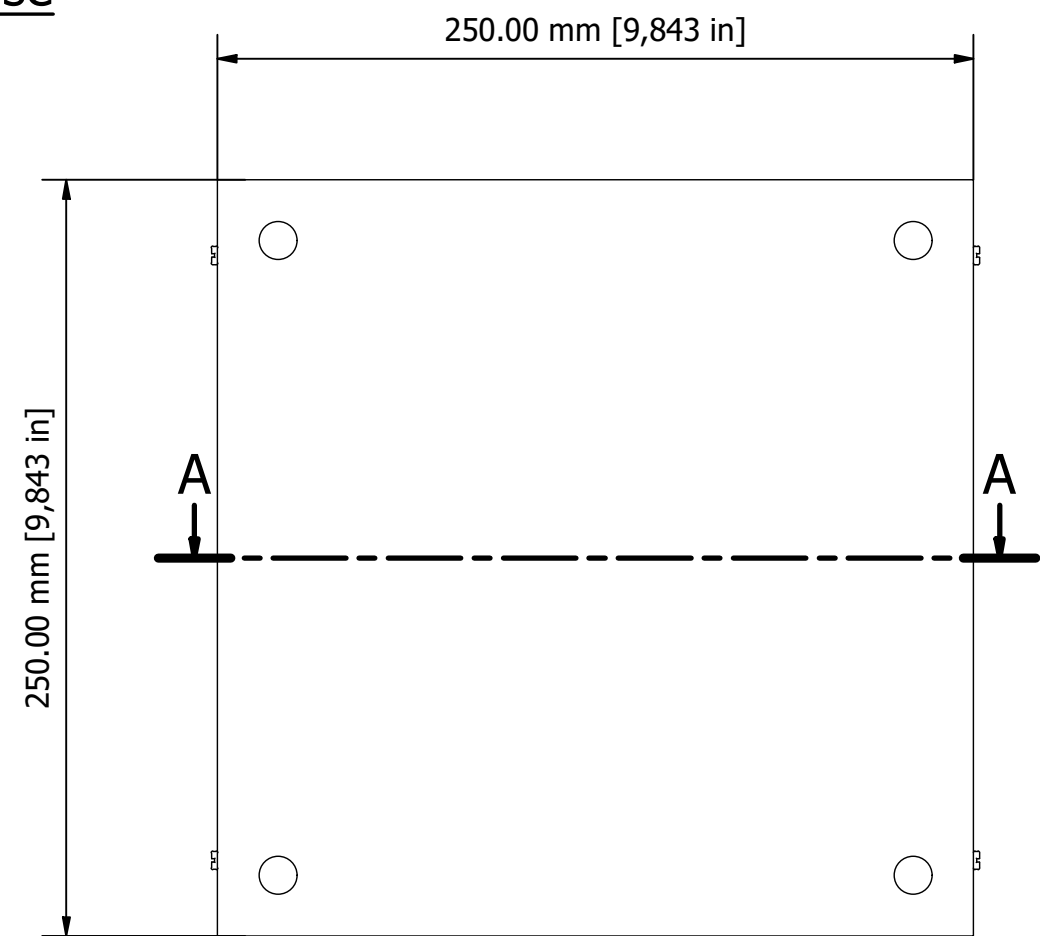

PARTS LIST			
ITEM	QTY	PART NUMBER	DESCRIPTION
3	1	M5403016	Unicase Assembly Kit
4	2	M5400003	Extrusion
5	1	M5409153	Base Panel
6	1	M5409053	Top Panel
7	2	M5402023	Front/Rear Panel

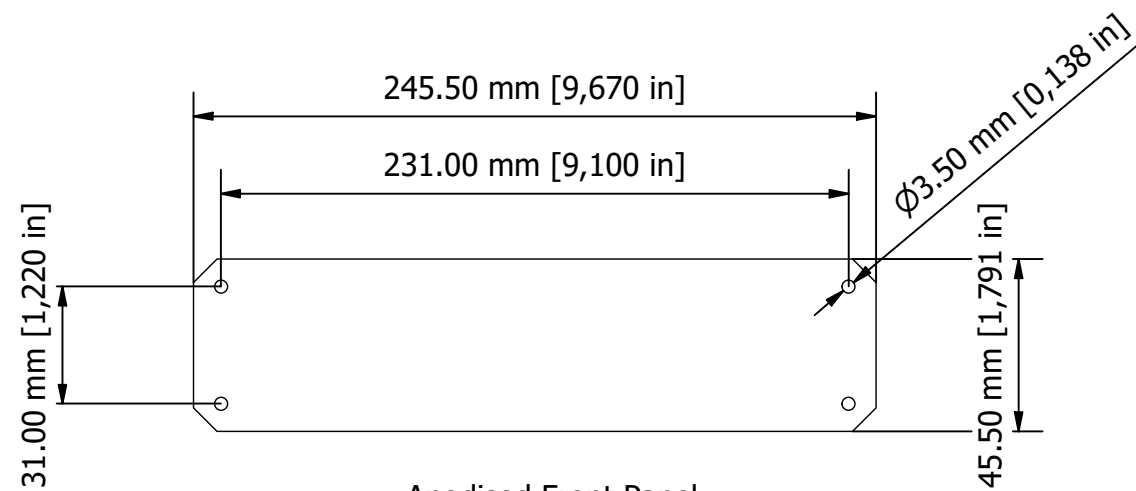

Anodised Front Panel  
2 off - 2mm Thick.

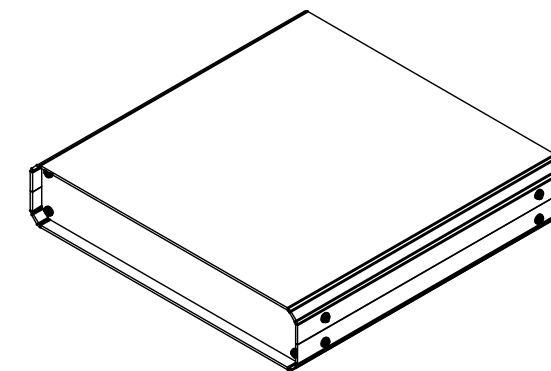

**Front**

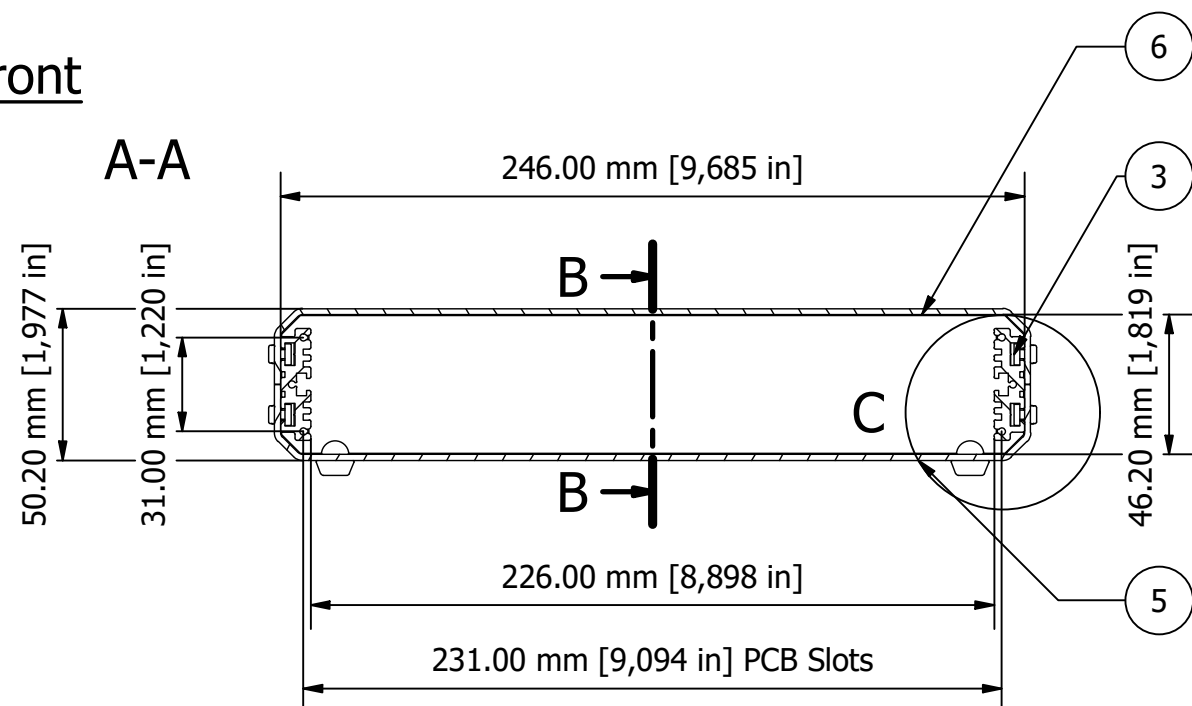

**Side**

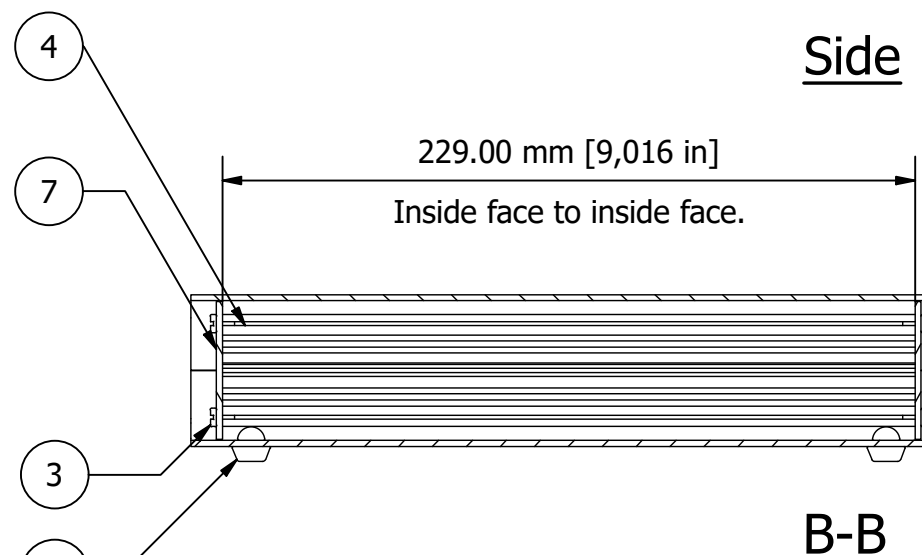

**Detail C**

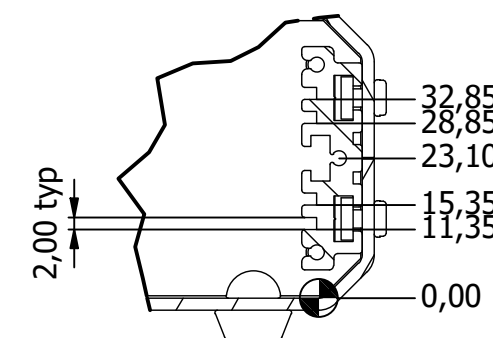

FIRST ANGLE PROJECTION

Designed by L Clark	Description UNICASE SL3 BLACK	Date 02/07/2013	Scale 1:2.5
<b>METCASE ENCLOSURES</b> 15 Brunel Way, Segensworth East, Fareham, Hampshire, UK. PO15 5TX Tel: +44 (0)1489 583858 Email: metcase@okw.co.uk		<b>METcase™</b> www.metcase.com Part Number M5513119	
		Issue 1	Sheet 1 / 1

© OKW Enclosures Ltd (Date as shown). This drawing contains proprietary information of OKW Enclosures Ltd and is tendered subject to the following conditions. The information be retained in confidence, not be reproduced or copied, and not be used or incorporated in any product, unless permission is obtained in writing from OKW Enclosures Ltd.